

Technical Specifications

- Freely install your own Linux-based software
- CPU: 3.20 GHz Intel(R) Core(R) CPU
- RAM: Up to 32GB DDR4-2400
- Storage: 16G MSATA SSD onboard and 2.5 inch SATA HDD
- NIC: 2* 10/100/1000M
- Power Supply: 12V/5A
- Display: Standard HDMI
- USB: 2
- Power Consumption: 60W
- Operating Temperature: 0°C to 50 °C
- Storage Temperature: -40 °C ~ 125 °C
- Humidity: 10 ~ 90% NON-CONDENSING

OpenVox VS-CCU-I5 Motherboard

Overview

VS-CCU-I5 is a new version asterisk® motherboard. With intel Quad Core processors, VS-CCU-I5 can easily handle 1600 concurrent calls with G.711 codec or 800 concurrent calls with G.729 codec. To bring you clear, high fidelity and high definition audio/video calls, VS-CCU-I5 can easily integrate with abundant HD voice and video codecs.

The VS-CCU-I5 supports comprehensive protocol processing, including SIP, IAX2 protocols in IP side and BRI, PRI, SS7, R2, GSM, WCDMA in CPE side. Taking the full advantages of open source platform, the VS-CCU-I5 will be preloaded with Elastix®, PBX in a Flash™, FreePBX IPPBX software.

Warranty

- Two-Year Warranty
- 3-Month "No-Question Asked Return Policy"

Certifications

- RoHS Complaint

Software & Platform:

- Issabel , Elastix , FreePBX , VitalPBX , BrikerPBX

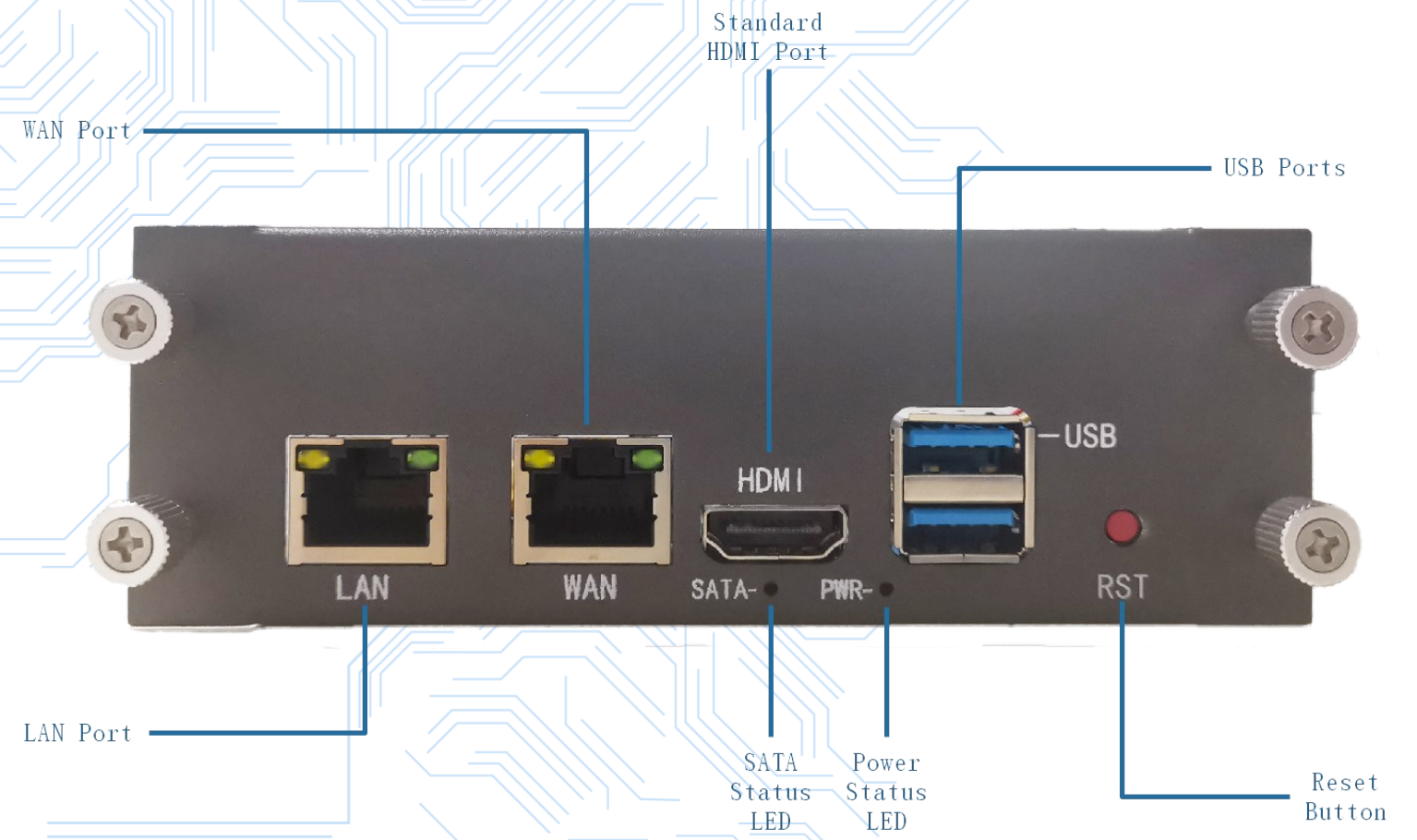

Features

- Users: Unlimited
- Max VoIP Trunks: Unlimited
- Max Concurrent Calls: 1600 Concurrent Calls with G.711 Codec, 800 Concurrent Calls with G.729 Codec
- Transport Protocol: UDP, TCP, TLS, SRTP
- DTMF: In-band, RFC2833, SIP INFO
- IP Services: Static IP, DHCP, VPN, Firewall, PPPoE, Bridge
- Supported codecs: ADPCM, G.711(A-Law & u-Law), G.722, G.723.1(pass through), G.726, G.728, G.729, GSM, iLBC (optional) among others.
- SIP and IAX2 support
- Web-based operator panel
- DISA(Direct Inward System Access)

Preloaded System

- Elastix 2.5 x86_64
- Elastix 4.0 x86_64
- Issabel-20170714 x86_64
- FreePBX-1712 x86_64

The default preloaded system is Issabel-20170714 x86_64.

- Call detail record(CDR) report
- Call recording, Call parking, call queues, Voicemail, Conference
- Echo canceller
- Callback support
- Flexible and configuration IVR
- Support for PIN sets
- Support for time conditions
- VOIP provider configuration
- Support for follow-me
- Support for ring groups
- Support for video-phones
- Channel usage reports